

MINI-T STATIC PIPEBURSTER

SPECIFICATIONS & DATA SHEET

Machine passes through $\text{Ø}600 \text{ mm.}$ shaft-entry
($\text{Ø}23.6 \text{ inch.}$)

Mini-T machine diameter $\text{Ø}480 \text{ mm.}$
($\text{Ø}18.9 \text{ inch.}$)

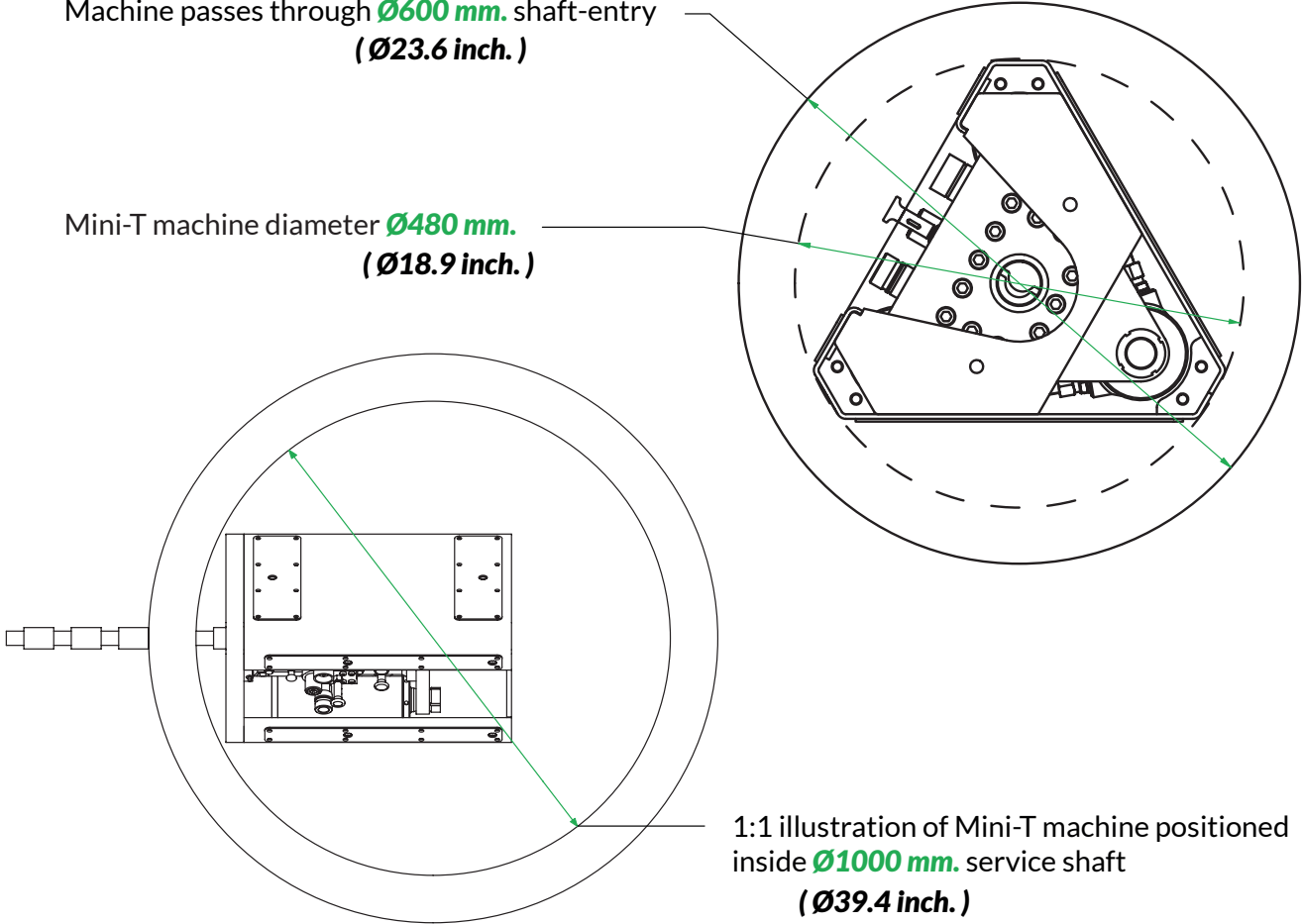

Length and height of Mini-T unit inside service shaft (side view).
Steel-rod exit level from bottom of service shaft: 148 mm. (5.8 inch.)

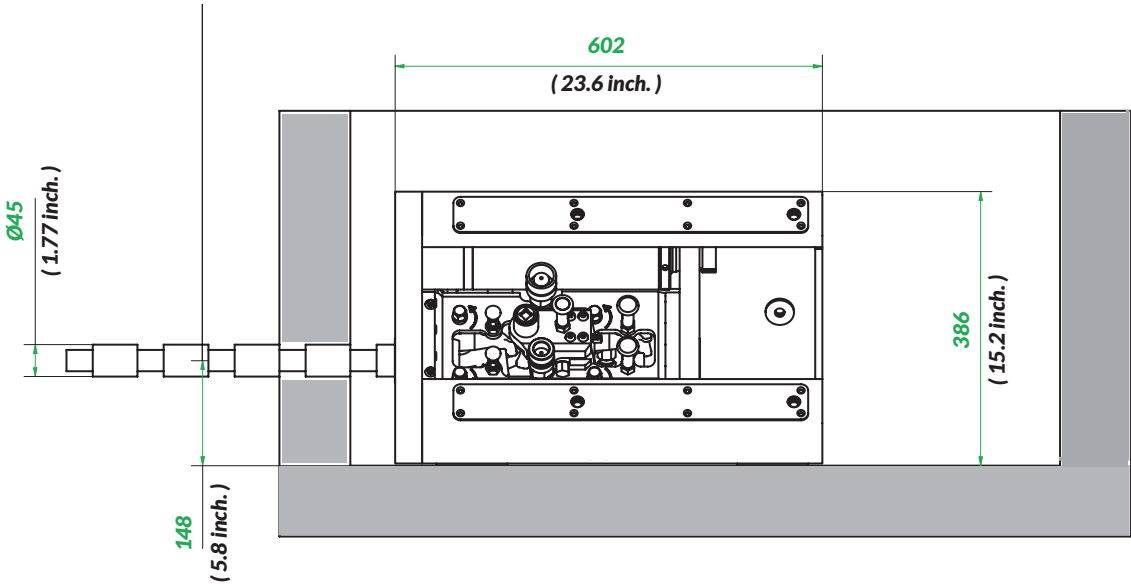

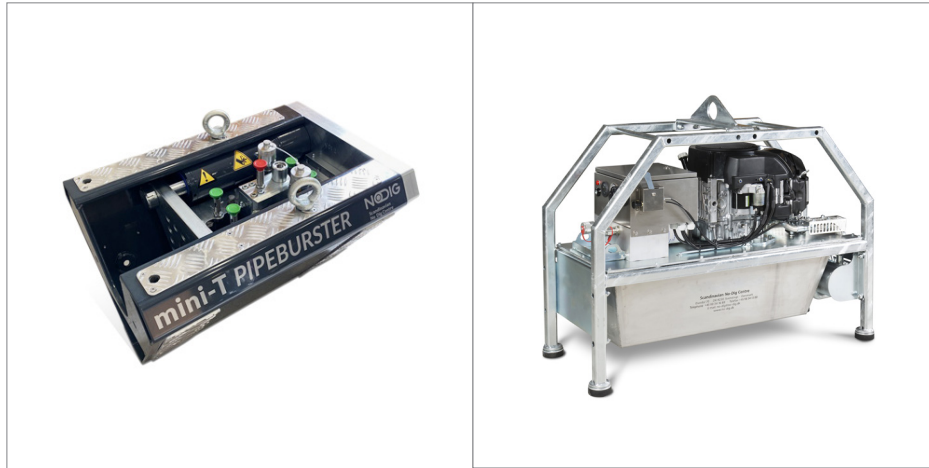

Mini-T

Hydro-static pipeburster with 37 metric tons of pulling power (81600 lbs.)

Hydraulic Power Pack

21 bhp. gasoline hydraulic Power Pack. Max. pressure 250 bar.

| Specifications | Pulling unit | Power pack | Steel rods |
|--|--|---|--|
| Pulling force | 37 metric tons (81600 lbs.) | | |
| Measurements | 60 x 44 x 48 cm. (23.6 x 17.3 x 18.9 inch.) | 122 x 65 x 100 cm. (48.0 x 25.6 x 39.4 inch.) | Std. Ø45 mm. x 0.30 meter. (1.77 x 11.80 inch.) Option Ø30 mm. x 0.30 meter. (1.18 x 11.80 inch.) |
| Weight | 158 kg. (348 lbs.) | 250 kg. (550 lbs.) | Ø45 mm. steel rod: 2.90 kg. (6.4 lbs.) Ø30 mm. steel rod: 1.35 kg. (3.0 lbs.) |
| Engine | | Vanguard Petrol air-cooled 22 bhp. / 16.40 kW. Electrical start, 4-stroke Fuel cap. 20 ltr. (4.4 gal.) Fuel consumption: 4 ltr. / hr. (0.9 gal. /hr.) | |
| Hydraulic system | 3 cylinders | 250 bar / 3625 psi. Pump cap: 18 ltr. / min. 2500 rpm. (3.95 gal. / min. / 2500 rpm.) Hydraulic oil cap. 60 ltr. (13.2 gal.) | |
| Operational speed | Up to 1.0 meter. / min. (3.3 ft. / min) Cylinder stroke: 10 cm. (3.9 inch.) | | |
| Operational range, Existing pipe diameter | Ø40 mm. → Ø250 mm. (1.5 → 10.0 inch.) | | |