

MAXI-T ELECTRO-STATIC PIPEBURSTER

SPECIFICATIONS & DATA SHEET

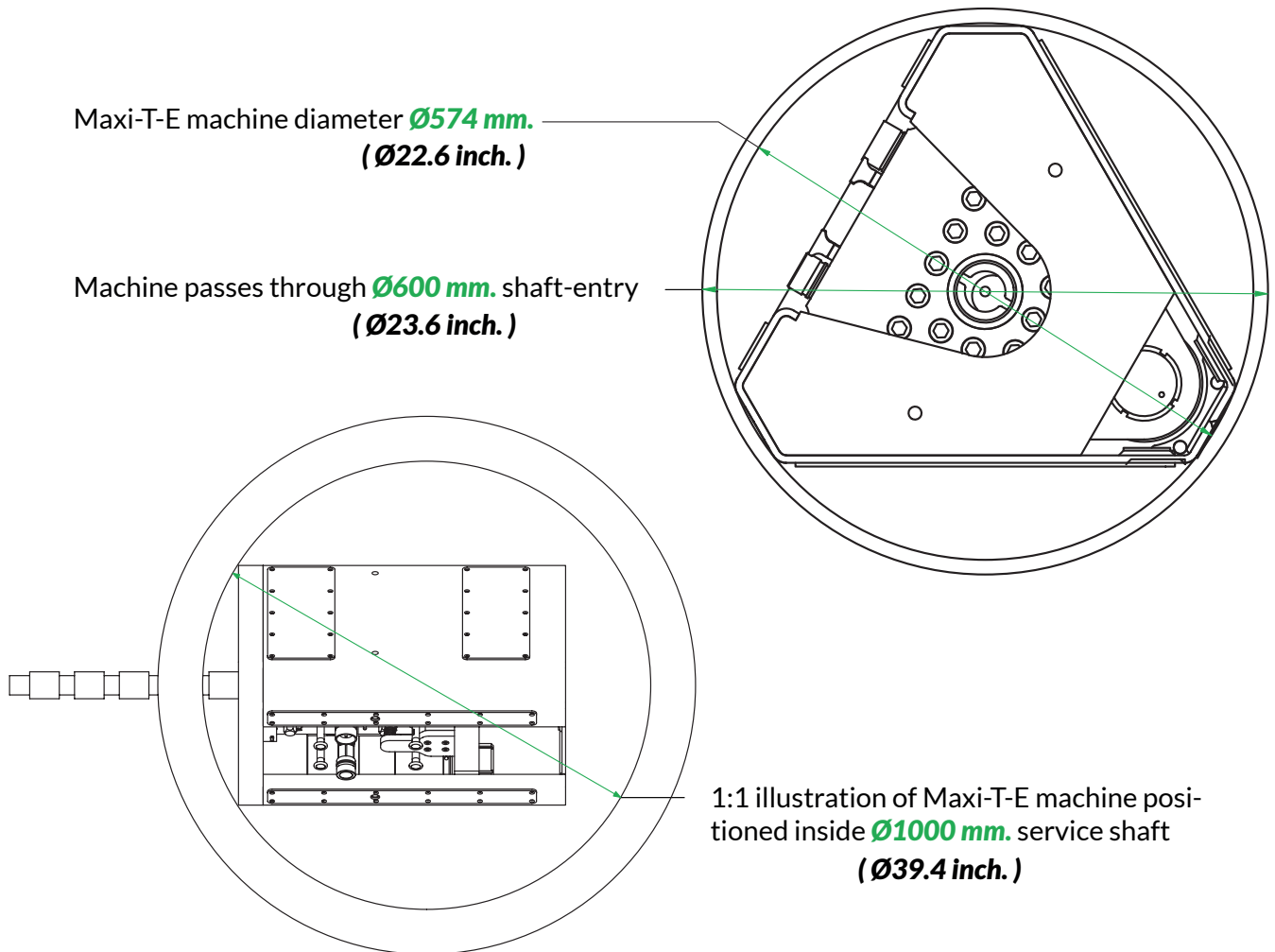

Length and height of Maxi-T-E unit inside service shaft (side view).
Steel-rod exit level from bottom of service shaft: **187 mm. (7.4 inch.)**

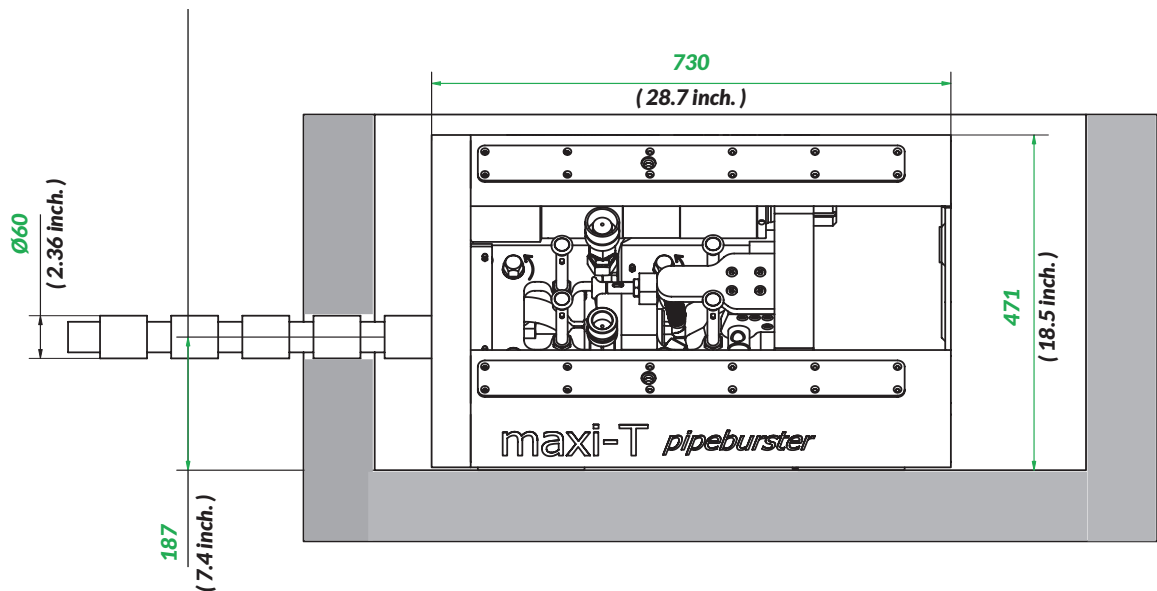

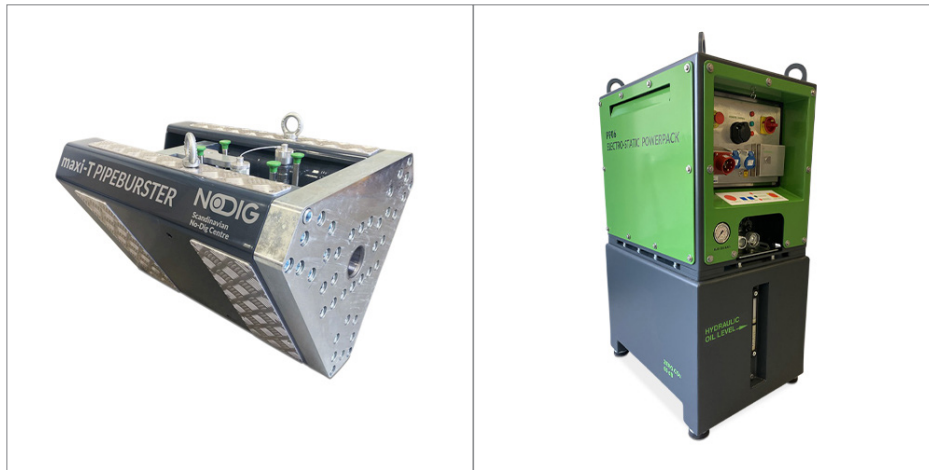

Maxi-T-E

Electro-static pipeburster with 60 metric tons of pulling power (134400 lbs.)

PP07 Electric Power Pack

7.5 kW electric engine / 250 bar op. pressure.

Specifications	Pulling unit	Power pack	Steel rods
Pulling force	60 metric tons (134400 lbs.)		
Measurements	73 x 54 x 58 cm. (28.7 x 21.3 x 22.8 inch.)	80 x 60 x 136 cm. (31.5 x 23.6 x 53.5 inch.)	Ø60 mm. x 0.33 meter (2.36 x 13.0 inch.)
Weight	380 kg. (838 lbs.)	630 kg. (1388 lbs.)	Ø60 mm. steel rod: 2.90 kg. (12.7 lbs.)
Engine		Electric engine 7.5 kW. 400 volt 15 amp. 50 Hz. Connection: 3P + N + PE CEE	
Hydraulic system	3 cylinders	250 bar / 3625 psi. 1 variable pump < 100 bar / 60 ltr. / min. (<1450 psi. / 15.8 gal. / min.) Hydraulic oil cap. 60 ltr. (15.8 gal.)	
Operational speed	Up to 0.6 meter. / min. (2 ft. / min.) Cylinder stroke: 11 cm. (4.3 inch.)		
Operational range, Existing pipe diameter	Ø80 mm. → Ø400 mm. (3.0 → 16 inch.)		